

EOLS-BIXX12-XXXX

1.25/1.063Gbps SFP Transceiver

Features

- ◆ Operating data rate up to 1.25Gbps
- ◆ A type: 1310nmFP Tx/1550nmRx
B type: 1550nmDFB Tx/1310nmRx
- ◆ Distance Up to 20 km
- ◆ Single 3.3V Power supply and TTL Logic Interface
- ◆ Simplex SC Connector Interface
- ◆ Hot Pluggable
- ◆ Operating Case Temperature
Standard: 0°C~+70°C ,
Industrial:-40°C~+85°C
- ◆ Compliant with MSA SFP Specification
- ◆ Digital diagnostic monitor interface
Compatible with SFF-8472



Applications

- ◆ SONET/SDH Equipment Interconnect
- ◆ Fiber Channel Links
- ◆ WDM Gigabit Ethernet Links

Product Description

The EOLS-BIXX12-XXXX series is small form factor pluggable module for Gigabit Ethernet 1000BASE-BX and Fiber Channel single fiber communications by using 1310 nm/1550nm transmitter and 1550 nm /1310nmreceiver. It is with the SFP 20-pin connector to allow hot plug capability.

The transmitter section uses a multiple quantum well A type/B type laser and is a class 1 laser compliant according to International Safety Standard IEC 60825. The receiver section uses an integrated B type/A type detector preamplifier (IDP) mounted in an optical header and a limiting post-amplifier IC.

The EOLS-BIXX12-XXXX series are designed to be compliant with SFF-8472 SFP Multi-source Agreement (MSA).

Absolute Maximum Ratings

Parameter	Symbol	Min.	Max.	Unit
Storage Temperature	T_s	-40	+85	°C
Supply Voltage	V_{CC}	-0.5	3.6	V

Recommended Operating Conditions

Parameter	Symbol	Min.	Typical	Max.	Unit	
Operating Temperature	T_A	EOLS-BIXX12-XX X	0		+70	°C
		EOLS-BIXX12-XXIX	-40		+85	
Power Supply Voltage	V_{CC}	3.15	3.3	3.45	V	
Power Supply Current	I_{CC}			190	mA	
Surge Current	I_{Surge}			+30	mA	
Baud Rate			1.25		GBaud	
Total Supply Current	I_{CC}			300	mA	
Surge Current	I_{surge}			+30	mA	

PERFORMANCE SPECIFICATIONS - ELECTRICAL

Parameter	Symbol	Min.	Typ.	Max	Unit	Notes
TRANSMITTER						
CML/PECL Inputs(Differential)	V_{in}	400		2500	mVp	AC coupled inputs
Input Impedance (Differential)	Z_{in}	85	100	115	ohms	$R_{in} > 100$ kohms @ DC
Tx_DISABLE Input Voltage - High		2		3.45	V	
Tx_DISABLE Input Voltage - Low		0		0.8	V	
Tx_FAULT Output Voltage -- High		$V_{cc}-0.5$		$V_{cc}+0.3$	V	$I_o = 400\mu A$; Host V_{cc}
Tx_FAULT Output Voltage -- Low		0		0.5	V	$I_o = -4.0mA$
RECEIVER						
CML Outputs (Differential)	V_{out}	400	800	1200	mVpp	AC coupled outputs
Output Impedance (Differential)	Z_{out}	85	100	115	ohms	
Rx_LOS Output Voltage - High		$V_{cc}-0.5$		$V_{cc}+0.3$	V	$I_o = 400\mu A$; Host V_{cc}

SFP SC Series 1.25/1.063G up to 20km transmission

Rx_LOS Output Voltage - Low		0		0.8	V	Io = -4.0mA
MOD_DEF (0:2)	VoH	2.5			V	With Serial ID
	VoL	0		0.5	V	

Optical and Electrical Characteristics

Parameter		Symbol	Min.	Typical	Max.	Unit
9µm Core Diameter SMF	EOLS-BIXX12-10XX			10		km
	EOLS-BIXX12-20XX			20		
Data Rate				1.25		Gbps
Transmitter						
Centre Wavelength	TYPE A	λ_C	1270	1310	1350	nm
	TYPE B		1500	1550	1580	
Spectral Width	TYPE A (RMS)	σ			4	nm
	TYPE B (-20dB)				1	
TYPE A Average Output Power	EOLS-BI1312-10XX	P_{out}	-9		-3	dBm
	EOLS-BI1312-20XX		-8		3	
TYPE B Average Output Power	EOLS-BI1512-10XX	P_{out}	-9		-3	dBm
	EOLS-BI1512-20XX		-8		-3	
Extinction Ratio		EX	9			dB
Rise/Fall Time(20%~80%)		tr/tf			90	ps
Total Jitter		TJ			1	ns
Output Optical Eye		IUT-T G.957 Compliant				
Data Input Swing Differential		V_{IN}	500		2000	mV
Input Differential Impedance		Z_{IN}	90	100	110	Ω
TX Disable	Disable		2.0		$V_{CC}+0.3$	V
	Enable		0		0.8	
TX_Fault	Fault		2.0		$V_{CC}+0.3$	V
	Normal		0		0.8	
TX_Disable Assert Time		t_off			10	s
Receiver						
Centre Wavelength	TYPE A	λ_C	1500	1550	1580	nm
	TYPE B		1270	1310	1360	
Sensitivity	10km	PIN			-20	dBm
	20km				-22	
Output Differential Impedance		P_{IN}	90	100	110	Ω
Data Output Swing Differential		V_{OUT}	370		2000	mV
Rise/Fall Time		Tr/tf			2.2	ns
LOS De-Assert		LOS_D			-24	dBm
LOS Assert		LOS_A	-40			dBm
LOS	High		2.0		$V_{CC}+0.3$	V
	Low		0		0.8	

SFP Transceiver Electrical Pad Layout

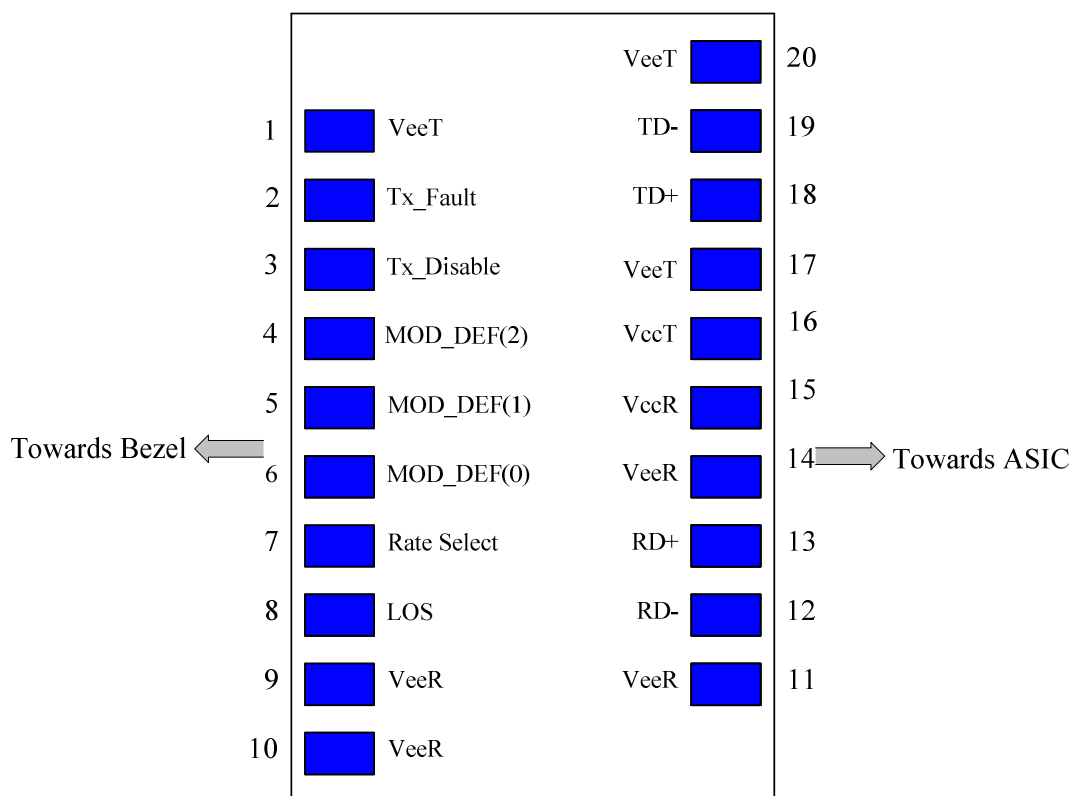

Pin Function Definitions

Pin Num.	Name	FUNCTION	Plug Seq.	Notes
1	VeeT	Transmitter Ground	1	
2	TX Fault	Transmitter Fault Indication	3	Note 1
3	TX Disable	Transmitter Disable	3	Note 2, Module disables on high or open
4	MOD-DEF2		3	Note 3, Data line for Serial ID.
5	MOD-DEF1	Module Definition 1	3	Note 3, Clock line for Serial ID.
6	MOD-DEF0	Module Definition 0	3	Note 3, Grounded within the module.
7	Rate Select	Not Connect	3	Function not available
8	LOS	Loss of Signal	3	Note 4
9	VeeR	Receiver Ground	1	Note 5
10	VeeR	Receiver Ground	1	Note 5

SFP SC Series 1.25/1.063G up to 20km transmission

11	VeeR	Receiver Ground	1	Note 5
12	RD-	Inv. Received Data Out	3	Note 6
13	RD+	Received Data Out	3	Note 7
14	VeeR	Receiver Ground	1	Note 5
15	VccR	Receiver Power	2	3.3 ± 5%, Note 7
16	VccT	Transmitter Power	2	3.3 ± 5%, Note 7
17	VeeT	Transmitter Ground	1	Note 5
18	TD+	Transmit Data In	3	Note 8
19	TD-	Inv. Transmit Data In	3	Note 8
20	VeeT	Transmitter Ground	1	Note 5

Notes:

1) TX Fault is an open collector/drain output, which should be pulled up with a 4.7K – 10KΩ resistor on the host board. Pull up voltage between 2.0V and VccT, R+0.3V. When high, output indicates a laser fault of some kind. Low indicates normal operation. In the low state, the output will be pulled to < 0.8V.

2) TX disable is an input that is used to shut down the transmitter optical output. It is pulled up within the module with a 4.7 – 10 K Ω resistor. Its states are:

Low (0 – 0.8V): Transmitter on

(>0.8, < 2.0V): Undefined

High (2.0 – 3.465V): Transmitter Disabled

Open: Transmitter Disabled

3) Mod-Def 0,1,2. These are the module definition pins. They should be pulled up with a 4.7K – 10KΩ resistor on the host board. The pull-up voltage shall be VccT or VccR (see Section IV for further details). Mod-Def 0 is grounded by the module to indicate that the module is present Mod-Def 1 is the clock line of two wire serial interface for serial ID Mod-Def 2 is the data line of two wire serial interface for serial ID

4) LOS (Loss of Signal) is an open collector/drain output, which should be pulled up with a 4.7K – 10KΩ resistor. Pull up voltage between 2.0V and VccT, R+0.3V. When high, this output indicates the received optical power is below the worst-case receiver sensitivity (as defined by the standard in use). Low indicates normal operation. In the low state, the output will be pulled to < 0.8V.

5) VeeR and VeeT may be internally connected within the SFP module.

6) RD-/+: These are the differential receiver outputs. They are AC coupled 100Ω differential lines which should be terminated with 100Ω (differential) at the user SERDES. The AC coupling is done inside the module and is thus not required on the host board. The voltage swing on these lines will be between 370 and 2000 mV differential (185 –1000 mV single ended) when properly terminated.

7) VccR and VccT are the receiver and transmitter power supplies. They are defined as 3.3V \pm 5% at the SFP connector pin. Maximum supply current is 300mA. Recommended host board power supply filtering is shown below. Inductors with DC resistance of less than 1 ohm should be used in order to maintain the required voltage at the SFP input pin with 3.3V supply voltage. When the recommended supply-filtering network is used, hot plugging of the SFP transceiver module will result in an inrush current of no more than 30mA greater than the steady state value. VccR and VccT may be internally connected within the SFP transceiver module.

8) TD-/+: These are the differential transmitter inputs. They are AC-coupled, differential lines with 100Ω differential termination inside the module. The AC coupling is done inside the module and is thus not required on the host board. The inputs will accept differential swings of 500 – 2400 mV (250 – 1200mV single-ended), though it is recommended that values between 500 and 1200 mV differential (250 – 600mV single-ended) be used for best EMI performance.

EEPROM

The serial interface uses the 2-wire serial CMOS EEPROM protocol defined for the ATMEL AT24C02/04 family of components. When the serial protocol is activated, the host generates the serial clock signal (SCL). The positive edge clocks data into those segments of the EEPROM that are not write protected within the SFP transceiver. The negative edge clocks data from the SFP transceiver. The serial data signal (SDA) is bi-directional for serial data transfer. The host uses SDA in conjunction with SCL to mark the start and end of serial protocol activation. The memories are organized as a series of 8-bit data words that can be addressed individually or sequentially.

The Module provides diagnostic information about the present operating conditions. The transceiver generates this diagnostic data by digitization of internal analog signals. Calibration and alarm/warning threshold data is written during device manufacture. Received power monitoring, transmitted power monitoring, bias current monitoring, supply voltage monitoring and temperature monitoring all are implemented. The diagnostic data are raw A/D values and must be converted to real world units using calibration constants stored in EEPROM locations 56 – 95 at wire serial bus address A2h. The digital diagnostic memory map specific data field define as following .For detail EEPROM information, please refer to the related document of SFF 8472 Rev 9.3

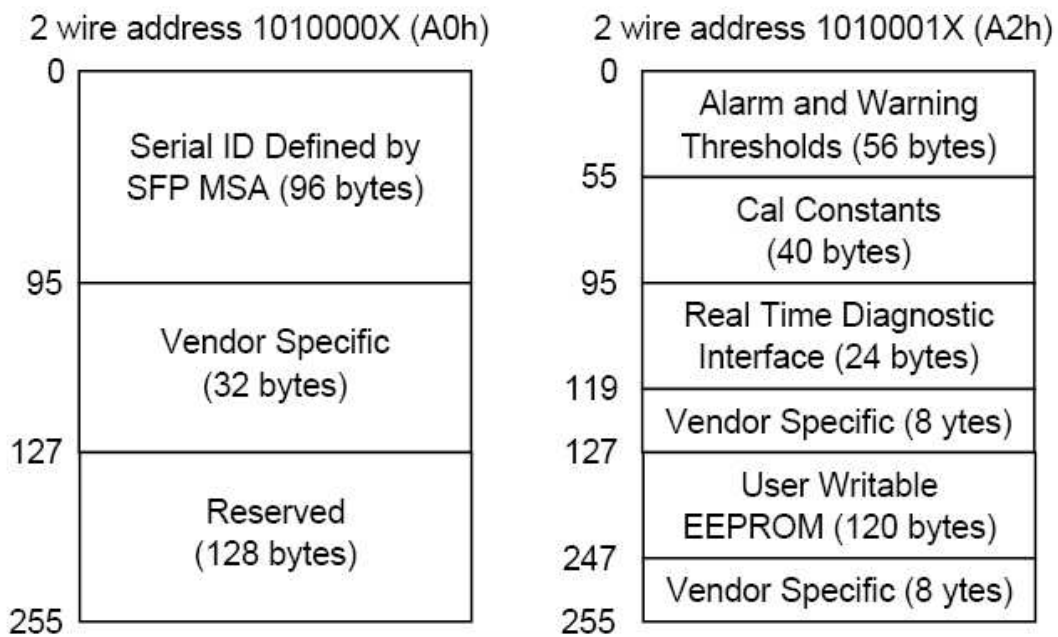

Recommend Circuit Schematic

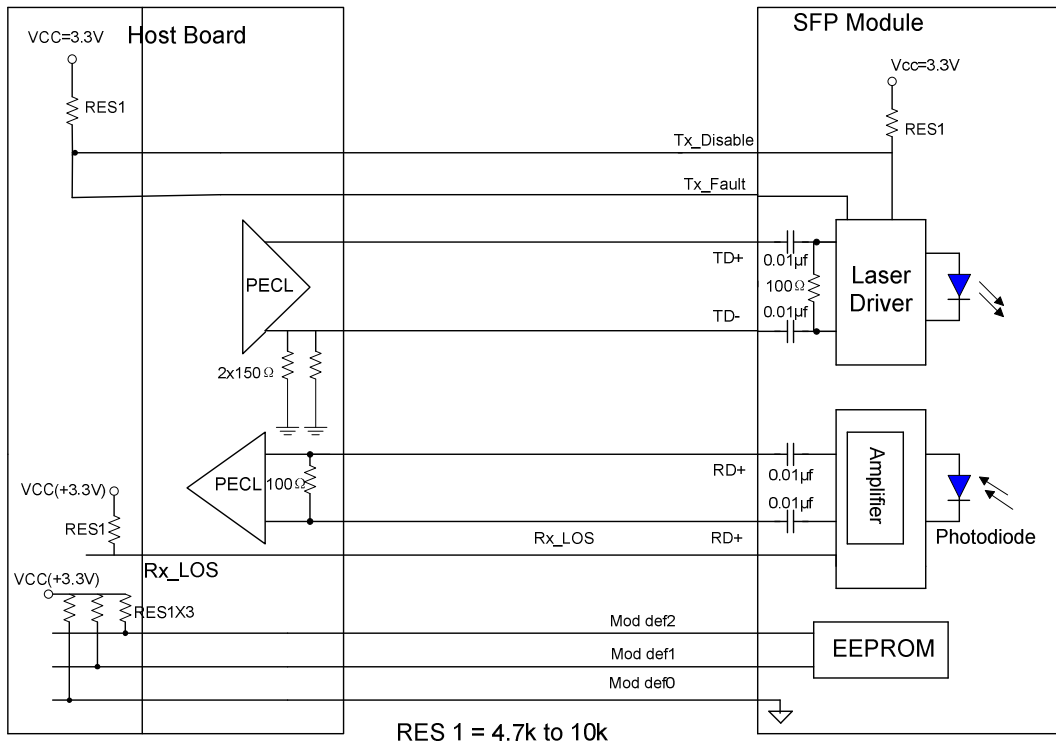

Mechanical Specifications

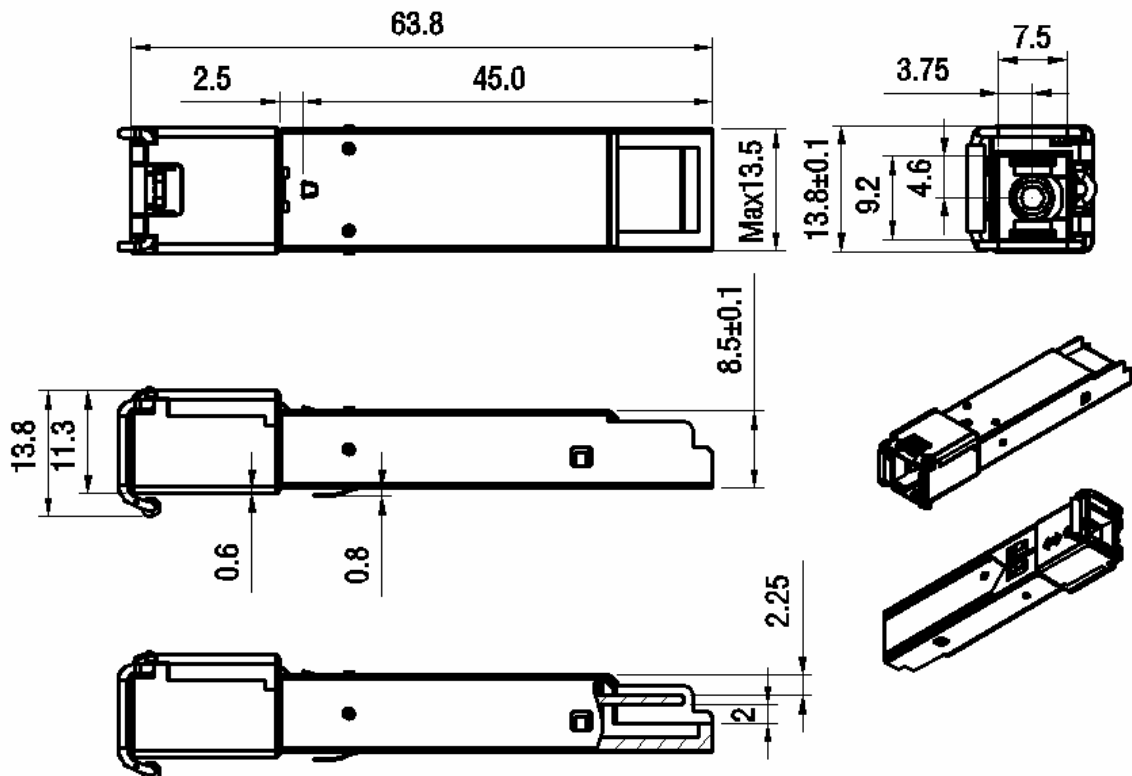

Ordering information

Part No.	Data Rate	Laser	Fibre Type	Distance	Optical Interface	DDMI
EOLS-BI1312-10	1.25/1.063 Gbps	1310nmFP	SMF	10Km	SC	NO
EOLS-BI1312-10D	1.25/1.063 Gbps	1310nmFP	SMF	10Km	SC	YES
EOLS-BI1312-10I	1.25/1.063 Gbps	1310nmFP	SMF	10Km	SC	NO
EOLS-BI1312-10ID	1.25/1.063 Gbps	1310nmFP	SMF	10Km	SC	YES
EOLS-BI1312-20	1.25/1.063 Gbps	1310nmFP	SMF	20Km	SC	NO
EOLS-BI1312-20D	1.25/1.063 Gbps	1310nmFP	SMF	20Km	SC	YES
EOLS-BI1312-20I	1.25/1.063 Gbps	1310nmFP	SMF	20Km	SC	NO
EOLS-BI1312-20ID	1.25/1.063 Gbps	1310nmFP	SMF	20Km	SC	YES
EOLS-BI1512-10	1.25/1.063 Gbps	1550nmDFB	SMF	10Km	SC	NO
EOLS-BI1512-10D	1.25/1.063 Gbps	1550nmDFB	SMF	10Km	SC	YES
EOLS-BI1512-10I	1.25/1.063 Gbps	1550nmDFB	SMF	10Km	SC	NO
EOLS-BI1512-10ID	1.25/1.063 Gbps	1550nmDFB	SMF	10Km	SC	YES
EOLS-BI1512-20	1.25/1.063 Gbps	1550nmDFB	SMF	20Km	SC	NO
EOLS-BI1512-20D	1.25/1.063 Gbps	1550nmDFB	SMF	20Km	SC	YES
EOLS-BI1512-20I	1.25/1.063 Gbps	1550nmDFB	SMF	20Km	SC	NO
EOLS-BI1512-20ID	1.25/1.063 Gbps	1550nmDFB	SMF	20Km	SC	YES

* I--- Industrial operating temperature

* D--- DDMI